

## Appendix C: Specifications for Street Design and Construction

### C-1: Design Speed, Sight Distance, Centerline Radius

	Minor	Major
Design Speed	25 mph	30 mph
Minimum Sight Distance on Vertical Curve	150 feet	200 feet
Minimum Centerline Radius	100 feet	200 feet

### C-2: Cut and Fill Slopes

Cut and fill slopes on any street right-of-way may not be steeper than 2:1.

### C-3: Sight Distances at Intersections

(a) At no-stop intersections, the intersection shall be constructed so that a person standing at a location on the centerline of any street 90 feet from the intersection of the street centerlines has an unobstructed view to a point located on the centerline of the intersecting street 90 feet (in either direction) from the intersection of the street centerlines. See Standard Drawing No. 1.

(b) Subject to Subsection (c), at stop intersections, the intersection shall be constructed so that a person standing 10 feet back of the intersection of right-of-way lines on the stop street has an unobstructed view to a point on the right-of-way line of the intersecting through street located 70 feet from the intersection of the right-of-way lines. See Standard Drawing No. 2.

(c) At stop intersections where a residential street intersects with a state maintained primary road, the intersection shall be constructed so that a person standing 30 feet back of the intersection of right-of-way lines on the stop street has an unobstructed view to a point on the centerline of the through street located 150 feet from the intersection of the street right-of-way lines. See Standard Drawing No. 3.

### C-4: Radius at Street Intersections

At street intersections, the intersections of the paved surfaces shall be rounded with a minimum radius as shown in Standard Drawings No. 4 and No. 5. Where streets intersect at less than right angles, a greater radius may be required.

### C-5: Clearing and Grubbing

Clearing and grubbing shall be performed within the limits shown on the plans. All timber, brush, roots, stumps, trees, or other vegetation cut during the clearing operations shall become the contractor's responsibility to dispose of, and shall be either removed from the project by him, or satisfactorily disposed of on-site.

Adopted on December 14th, 2000  
Effective on January 1<sup>st</sup>, 2001

## **C-6: Grading and Compaction**

Streets shall be graded in accordance with the lines and grade set by the engineer. Before placing curb and gutter or base on the graded subgrade, the subgrade shall be compacted to 90 percent AASHTO T99 for a depth of six inches and then shall be proof rolled in the presence of the engineer. Places that are found to be loose, or soft, or composed of unsuitable materials, whether in the subgrade or below it, must be dug out and refilled with suitable material. All embankments or fills shall be made in one-foot horizontal lifts of suitable material. The fill shall be rolled with a sheepsfoot roller after each lift, followed by a wheel roller, each weighing not less than eight tons.

## **C-7: Street Base**

Base course for streets shall generally be eight inches thick, unless otherwise directed by the Franklin County Highway Administrator, and shall be crushed stone conforming to Section 1007, *Aggregate for Base of the Missouri Standard Specifications for Highway Construction*, current edition. The stone base course shall be placed in four-inch layers, watered as necessary, and compacted to 100 percent AASHTO T99. The contractor shall be responsible for keeping the stone base free of contamination from clay or other foreign materials. Handling and placement of stone base shall all be in accordance with Franklin County Highway Department specifications.

## **C-8: Street Surfaces**

The asphalt surface course shall meet *Section 403, Asphalt Concrete Pavement of the Missouri Standard Specifications for Highway Construction*, current edition. The asphalt shall be placed in one two-inch layer, and shall be handled and placed in accordance with Franklin County Highway Department specifications. Concrete or chip and seal may be used upon approval of the Highway Administrator and shall conform to the Franklin County Highway Department specifications.

## **C-9: Pavement Section Variations**

Sections C-6, C-7, and C-8 set the standards that shall apply under normal soils conditions. Soil tests are to be run to for all street design and a pavement design made by a qualified soils engineer. Under these circumstances, the Franklin County Highway Administrator may allow pavement sections constructed to lesser standards than those set forth above (for good soils) or require pavement sections constructed to greater standards than those set forth above (for unstable soils).

## **C-10: Street Cross Sections**

Streets shall be constructed and utilities located in accordance with Standard Drawing No. 6 or No. 7.

## **C-11: Curb and Gutter**

Adopted on December 14th, 2000  
Effective on January 1<sup>st</sup>, 2001

(a) The concrete curb and gutter shall be constructed according to the lines and grades established by the engineer. The concrete shall meet the state highway requirements. The curb and gutter shall be 30 inches wide, and shall have a vertical curb face. The forms shall be of metal, free of marks or kinks, and shall be rigidly held in position. The engineer shall approve the positioning of the forms before concrete is poured. The concrete shall be placed in the forms in a manner to prevent segregation, and tamped or vibrated sufficiently to prevent honeycombs. The concrete shall be finished smooth and even by means of rollers or floats. Expansion joints shall be provided every 30 feet, and false joints every 10 feet.

(b) Curb and gutter shall be constructed in accordance with Standard Drawing No. 8.

### **C-12: Sidewalks**

Sidewalk construction shall be similar to street construction, with subgrade compacted to 90 percent AASHTO T99. Concrete sidewalks shall be four inches thick (increasing to six inches thick at driveway entrances), and shall be at least four feet wide. Expansion joints shall be provided every 30 feet; false joints at 10 feet.

### **C-13: Wheel Chair Ramps**

Where required, wheel chair ramps shall be constructed in accordance with Standard Drawing No. 9.

### **C-14: Stormwater Runoff Control**

(a) The minimum design frequency for storm runoff shall be 10 years for storm sewer collection and 25 years for cross drainage (i.e., drainage facilities crossing a street).

(b) All storm drainage pipe shall be reinforced concrete and no pipe may be smaller than 15 inches in diameter.

(c) Culvert outlet protection and swale erosion protection shall be designed based on a 10-year storm.

(d) All storm drainage structures and pipes shall be designed and constructed in accordance with Franklin County Highway Department specifications and Standard Drawings No. 10 through No. 14. However, in case of a conflict, the standard drawings shall prevail.

### ***C-15: Sedimentation Control***

Road shoulders, swales, back-of-curbs, and cut and fill banks shall be completely dressed up by the contractor and seeded as soon as possible, and any time ground will remain bare for more than 30 days during construction. During the growing off-season, mulching is the preferred method. St. Louis Metropolitan Sewer District drawings and specifications may be used as reference.

Adopted on December 14th, 2000  
Effective on January 1<sup>st</sup>, 2001

**Standard Drawing No. 1**  
**Recommended Street Connection**  
 Sight Distance for No-Stop Condition

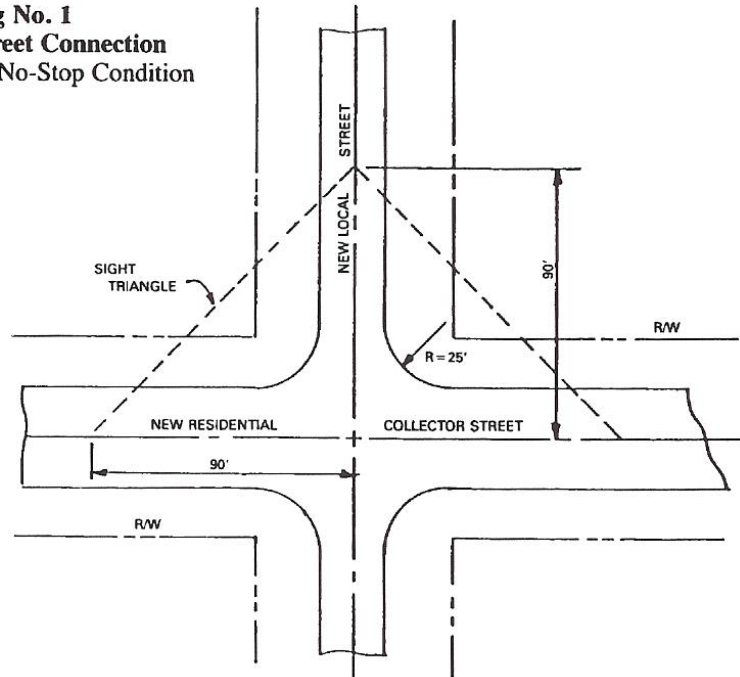

**Standard Drawing No. 2**  
**Recommended Street Connection**  
 Sight Distance for Stop Condition

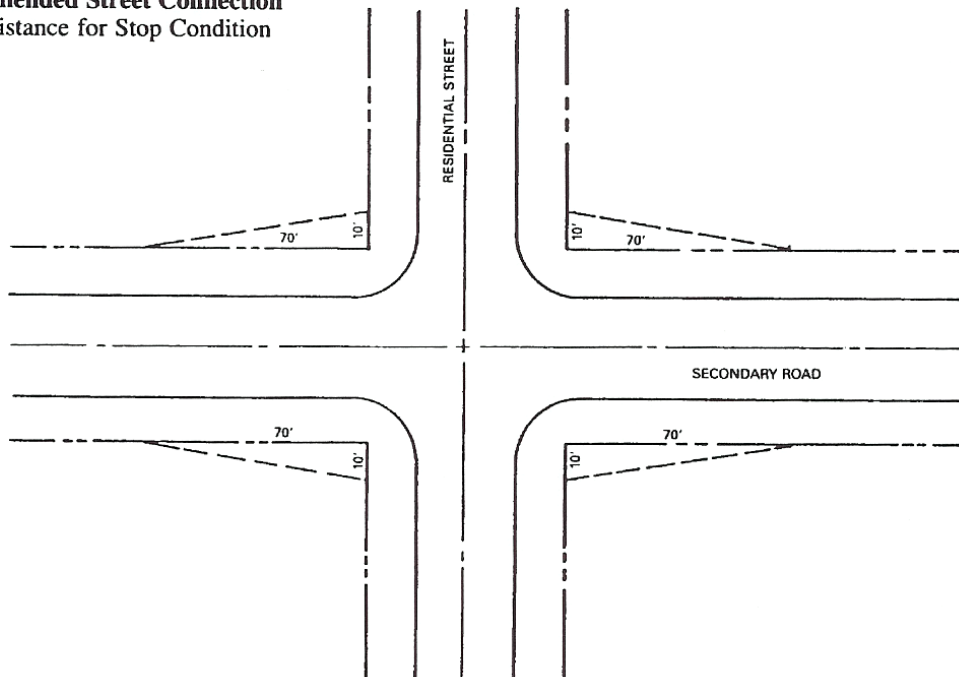

Effective on January 1<sup>st</sup>, 2001

**Standard Drawing No. 3**  
**Recommended Street Connection**  
 Sight Distance for Stop Condition

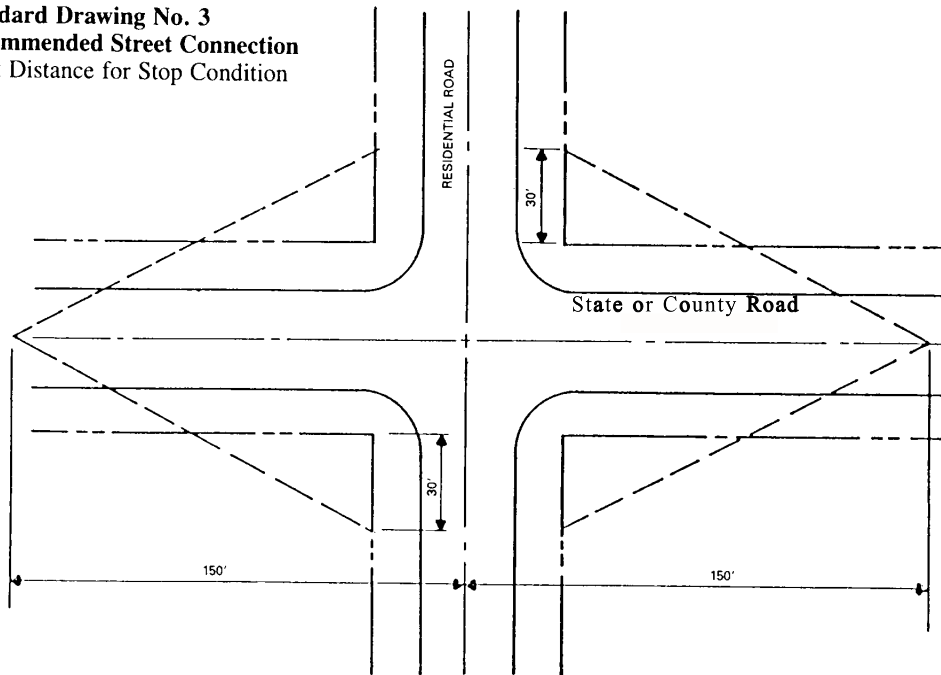

**Standard Drawing No. 4**  
**Recommended Street Connection**  
 Curb & Gutter

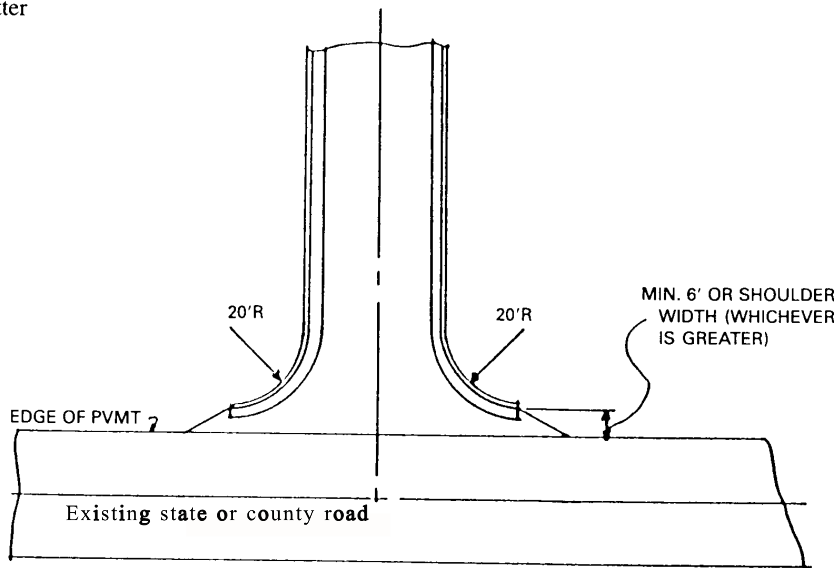

Adopted on December 14th, 2000  
 Effective on January 1<sup>st</sup>, 2001

**Standard Drawing No. 5**  
**Recommended Street Connection**  
 No Curb & Gutter

(An example of 20 foot road.)

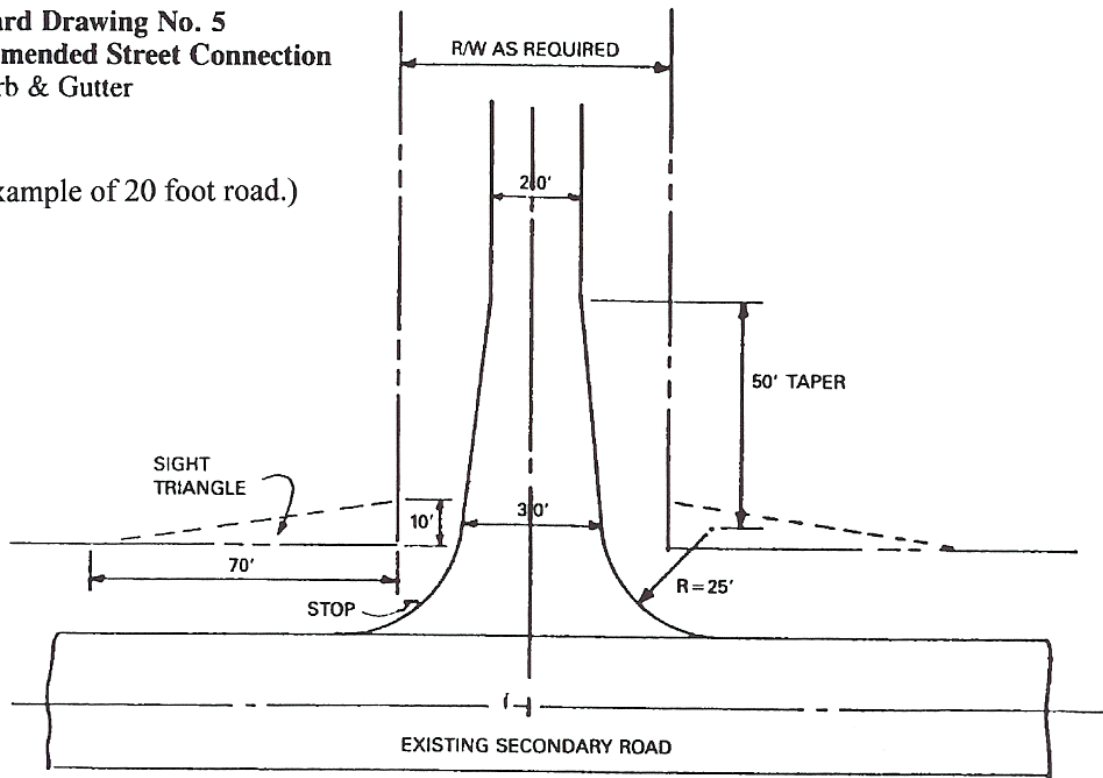

**Standard Drawing No. 6**  
**Residential Street**  
 No Curb & Gutter

Note: Shoulder shall be stabilized with 3 Type ABC stone, scarified into soil, compacted & seeded.

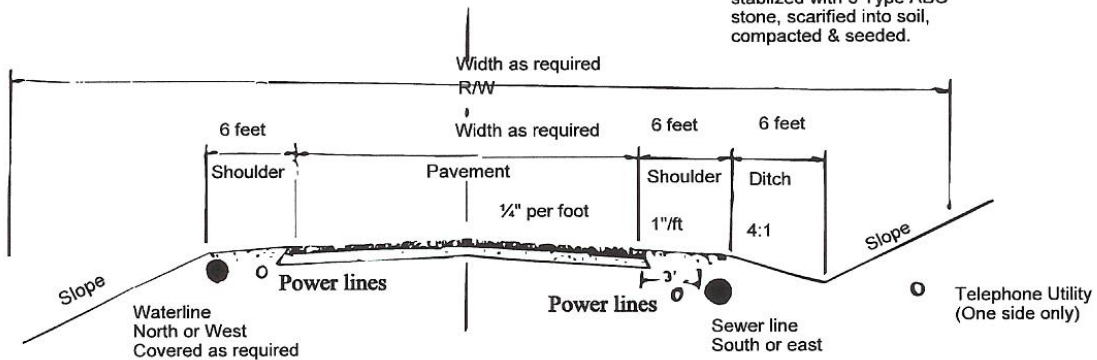

Terrain	Max Slope
Level	2:1
Rolling	2:1
Hilly	1 1/2 : 1

Adopted on December 14th, 2000  
 Effective on January 1<sup>st</sup>, 2001

**Standard Drawing No. 7**  
**Residential Street**  
**Curb & Gutter**

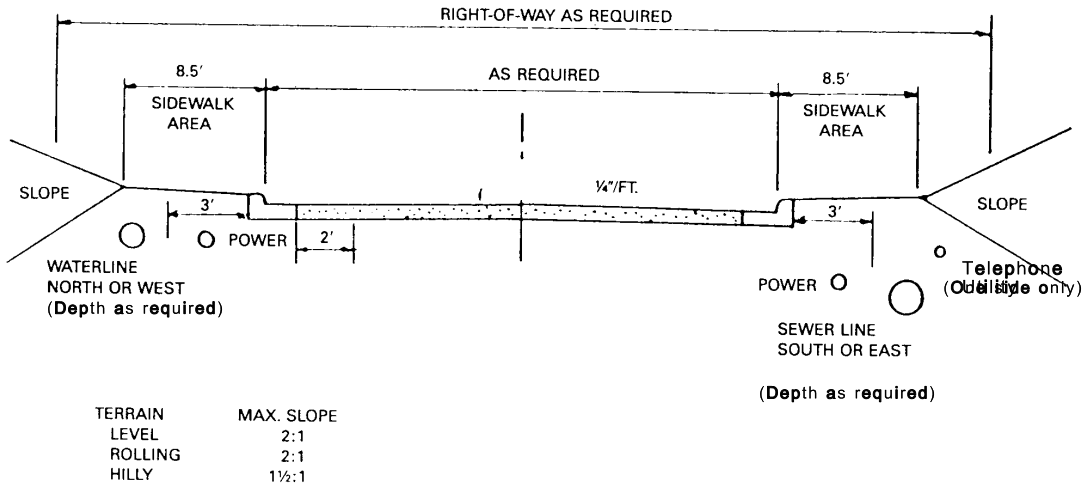

**Standard Drawing No. 8**  
**Standard Curb & Gutter**

**Concrete Driveway & Gutter**

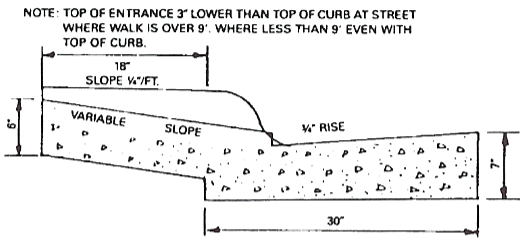

**Plan of Driveway Entrance**

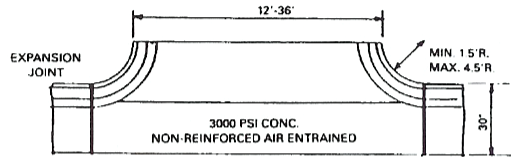

**Curb & Gutter**

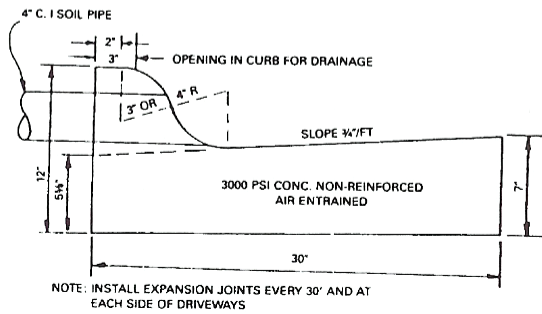

**Traffic Island Curb**

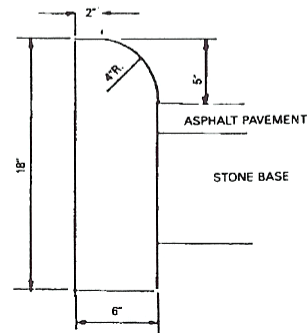

Adopted on December 14th, 2000  
 Effective on January 1<sup>st</sup>, 2001

Standard Drawing No. 9  
Standard Wheel Chair Ramp

Plan

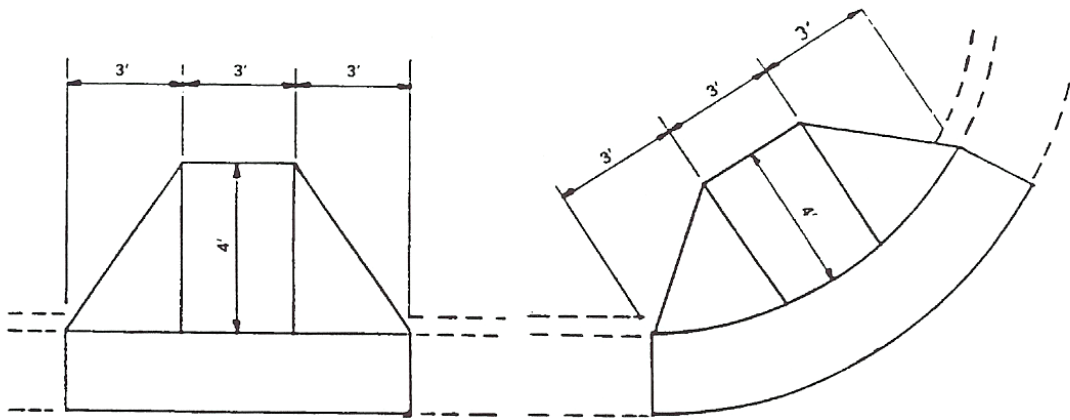

Front Elevation

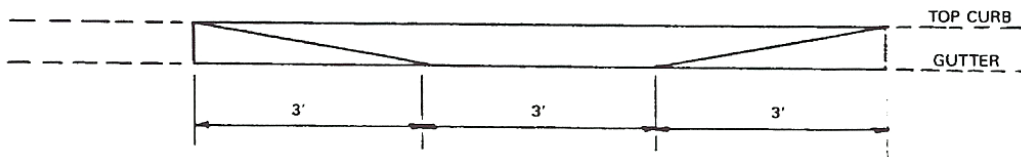

Section Thru Ramp

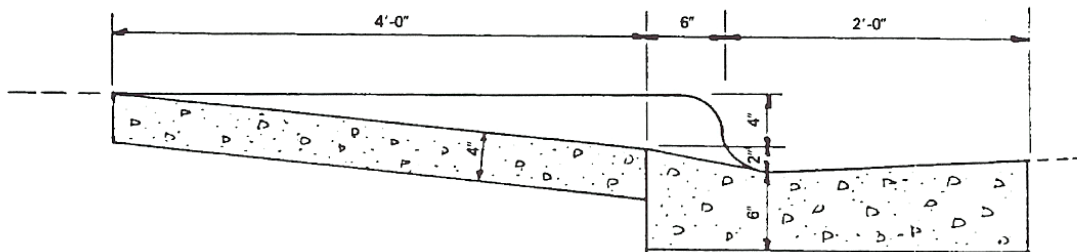

Adopted on December 14th, 2000  
Effective on January 1<sup>st</sup>, 2001



**Standard Drawing No. 10**  
**Standard Catch Basin**

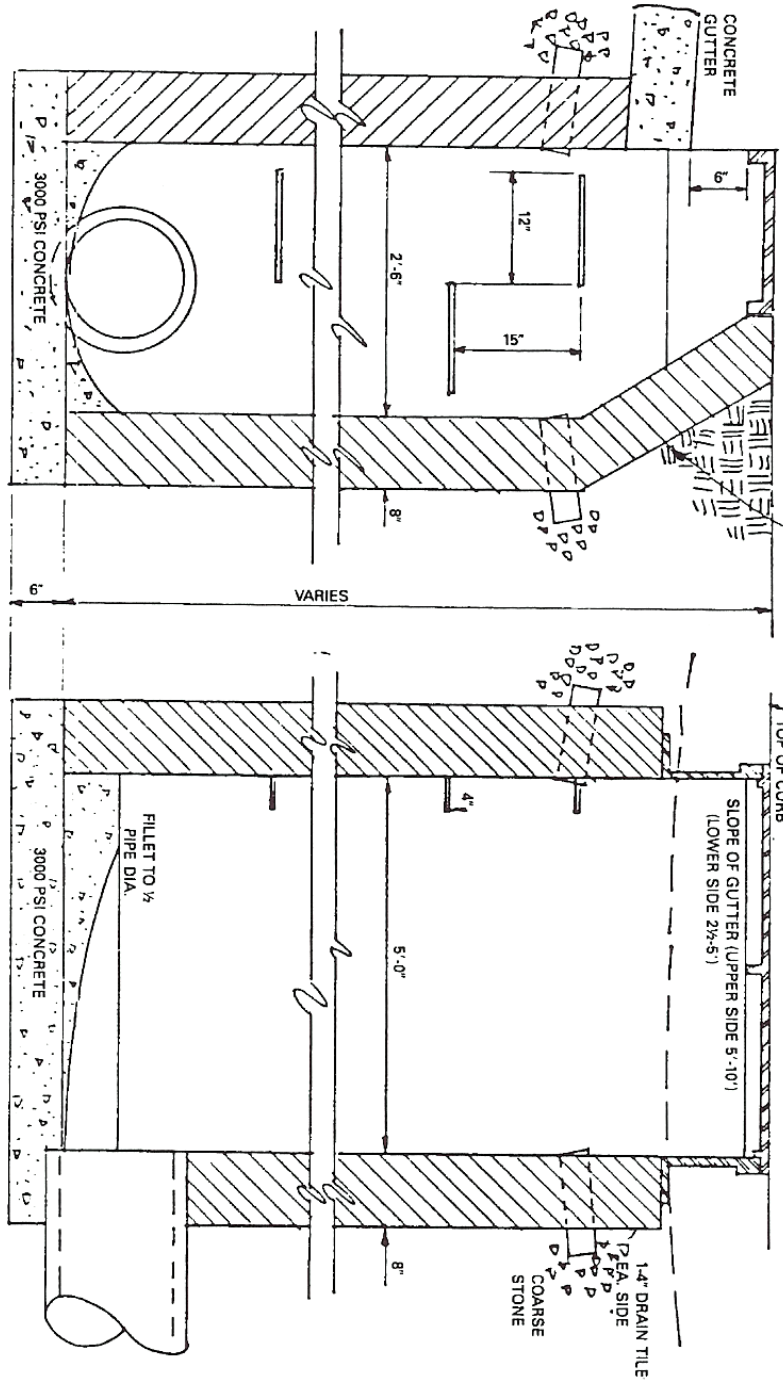

NOTE: PRECAST SLAB MAY BE  
 SUBSTITUTED FOR BRICKWORK

NOTE: CAST IRON MANHOLE STEPS SHALL BE INSTALLED  
 IN ALL CATCH BASINS OVER 4'-0" IN DEPTH. DEPTH SHALL  
 BE MEASURED FROM THE TOP OF GUTTER TO  
 INVERT OF CATCH BASIN.

Adopted on December 14th, 2000  
 Effective on January 1<sup>st</sup>, 2001

**Standard Drawing No. 11  
Storm Water Manhole**

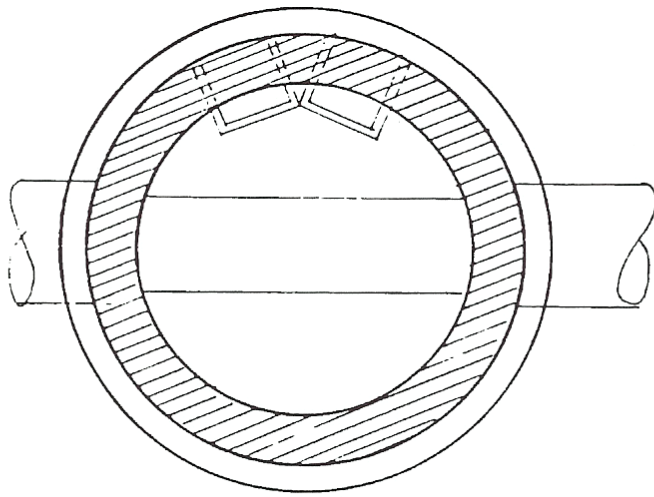
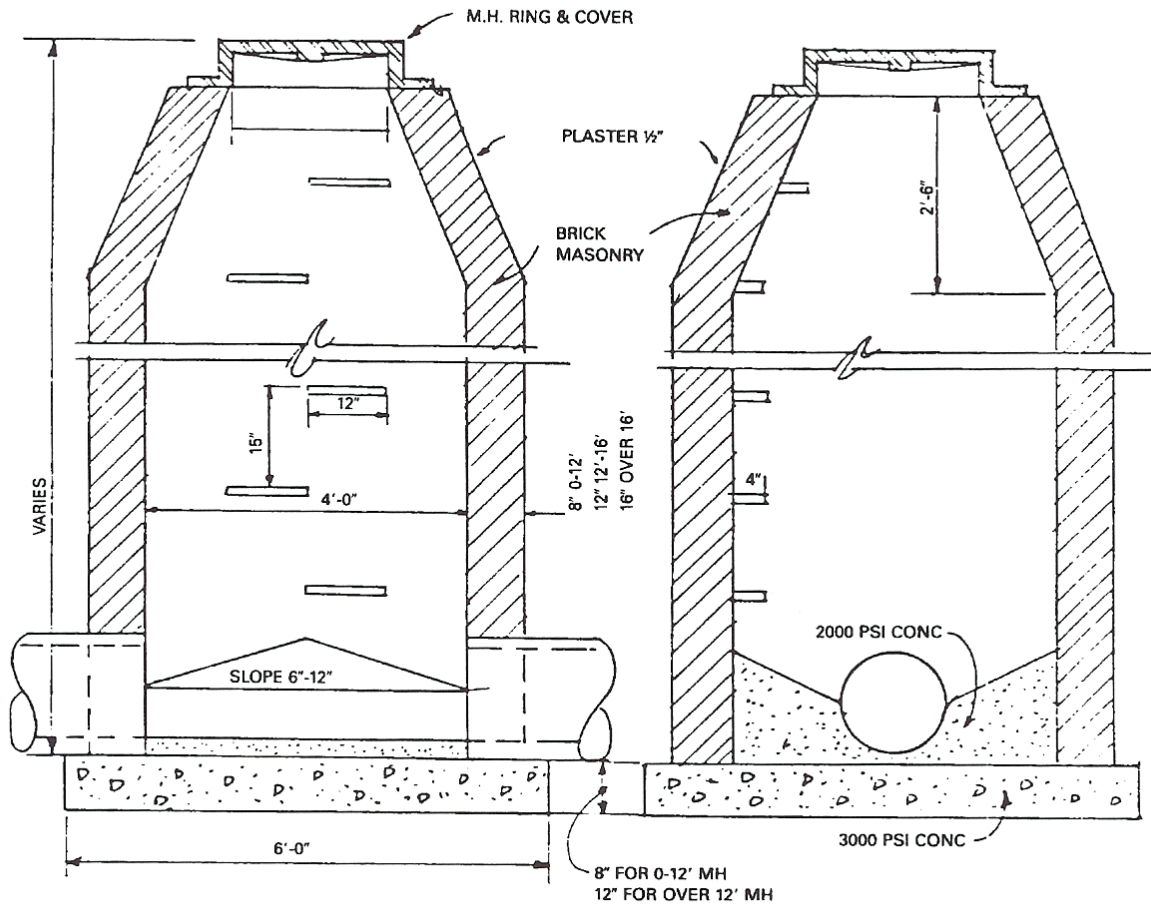

Adopted on December 14th, 2000  
Effective on January 1<sup>st</sup>, 2001

**Standard Drawing No. 12  
Yard Inlet Cover**

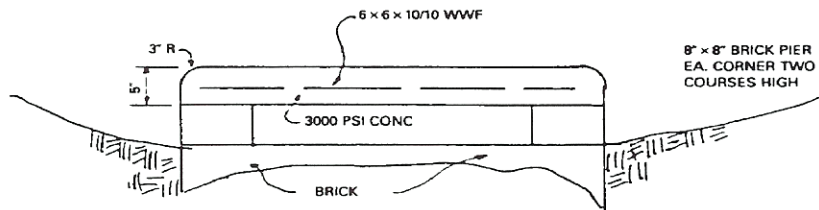
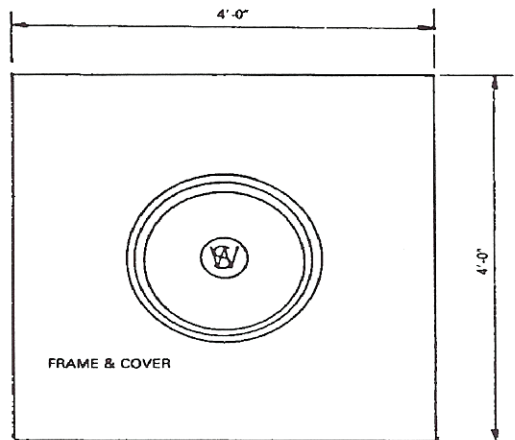

**Standard Drawing No. 13  
Yard Inlet**

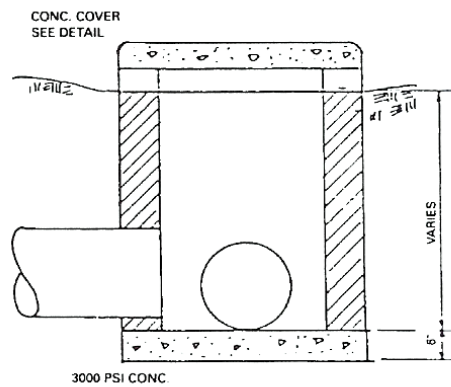
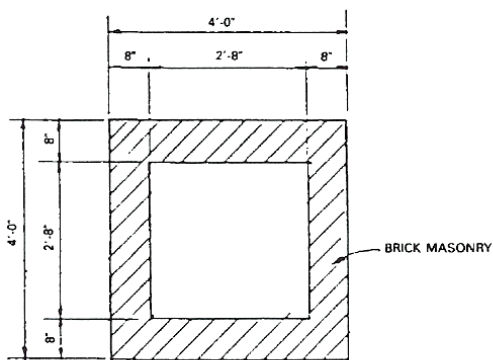

Adopted on December 14th, 2000  
Effective on January 1<sup>st</sup>, 2001

**Standard Drawing No. 14**  
**Sedimentation Control**

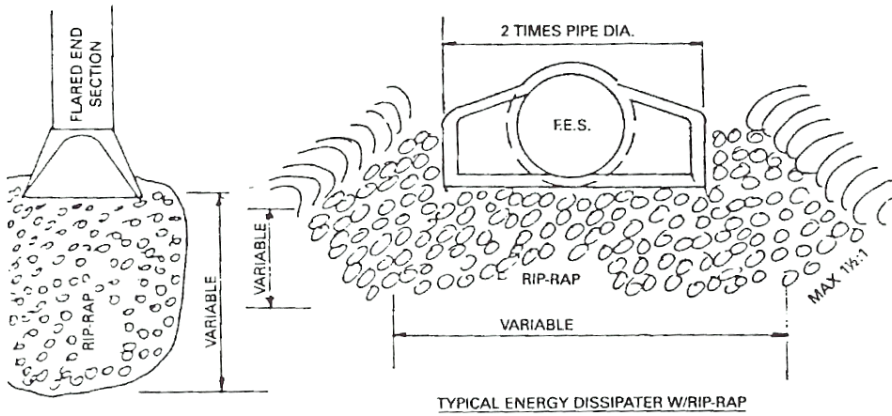
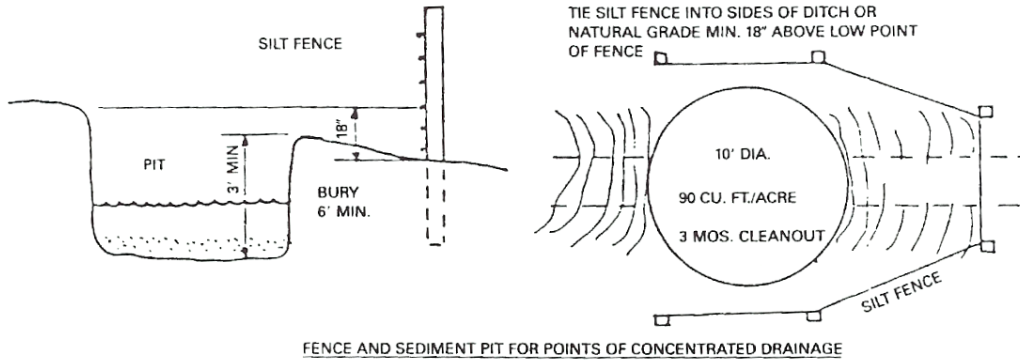

NOTE:  
 FLARED END PIPES GREATER THAN 36"  
 WILL REQUIRE CONC SLAB AND/OR RIP-RAP  
 TO PROTECT BOTH ENDS OF PIPE

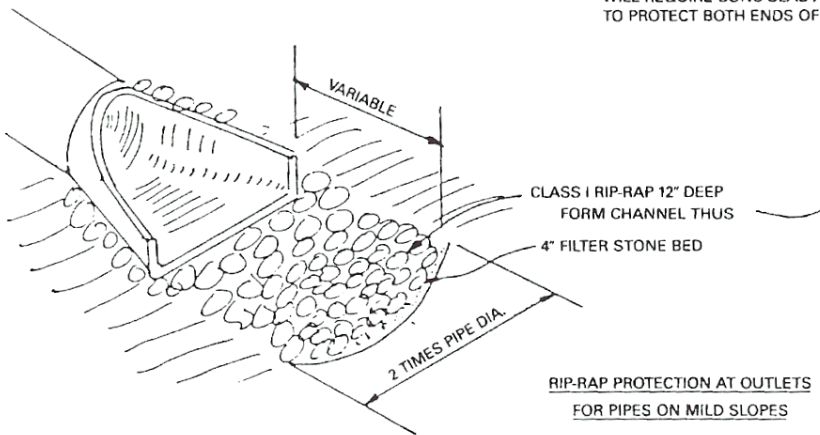

Adopted on December 14th, 2000  
 Effective on January 1<sup>st</sup>, 2001